

PEARSON YACHTS DIVISION OF  
GRUMMAN ALLIED INDUSTRIES, INC.

OPTIONAL 110V ELECTRICAL  
WIRING DIAGRAM  
FOR OWNERS MANUAL

P-323

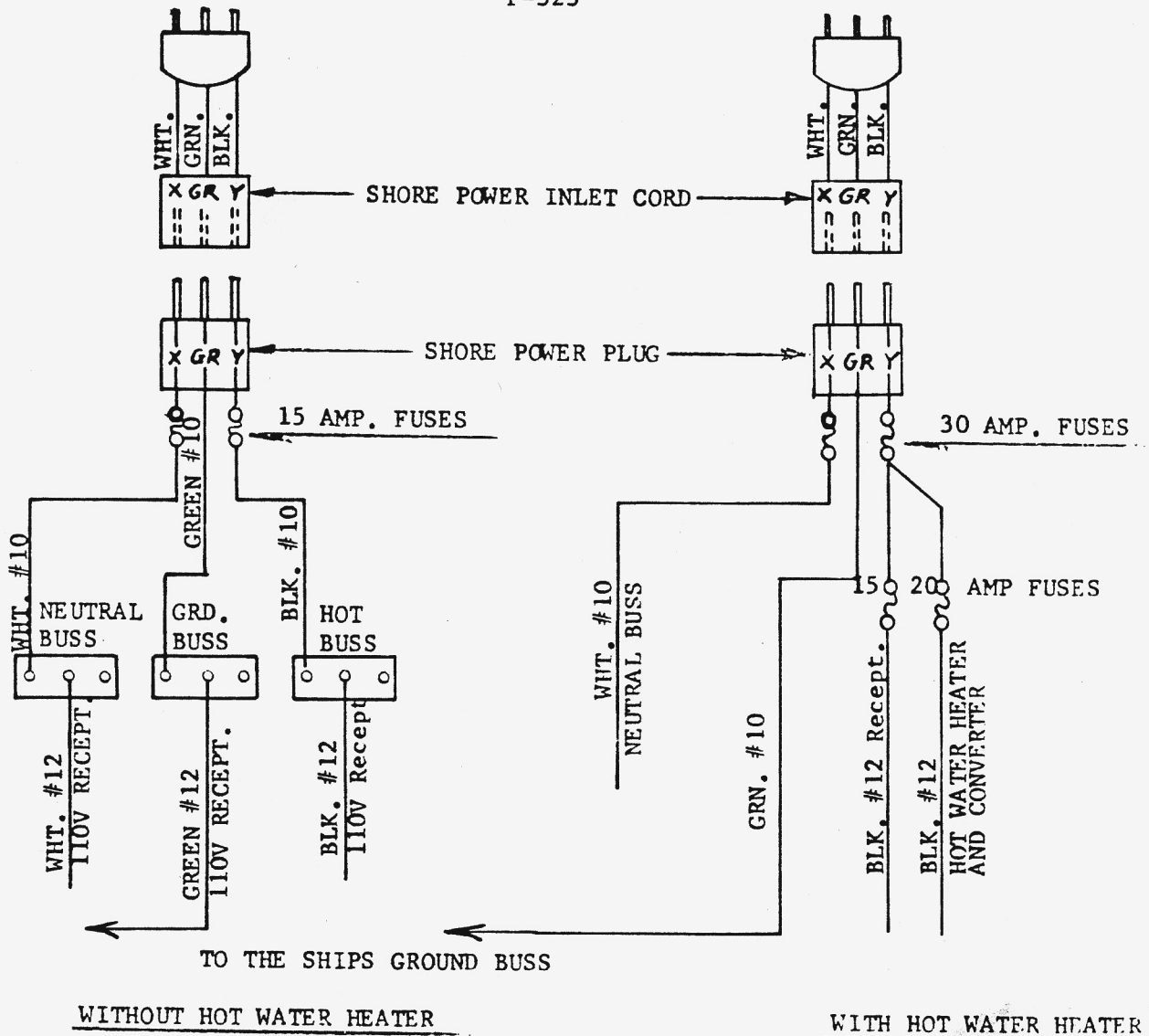

NOTE:

- 1 - The white, green, and black wires for the 110V system are included as part of the standard wiring harness.
- 2 - Any deviation from this wire color coding due to shortages will be documented with a copy included in the boat owners kit.