

P323 12vdc Wiring Diagram

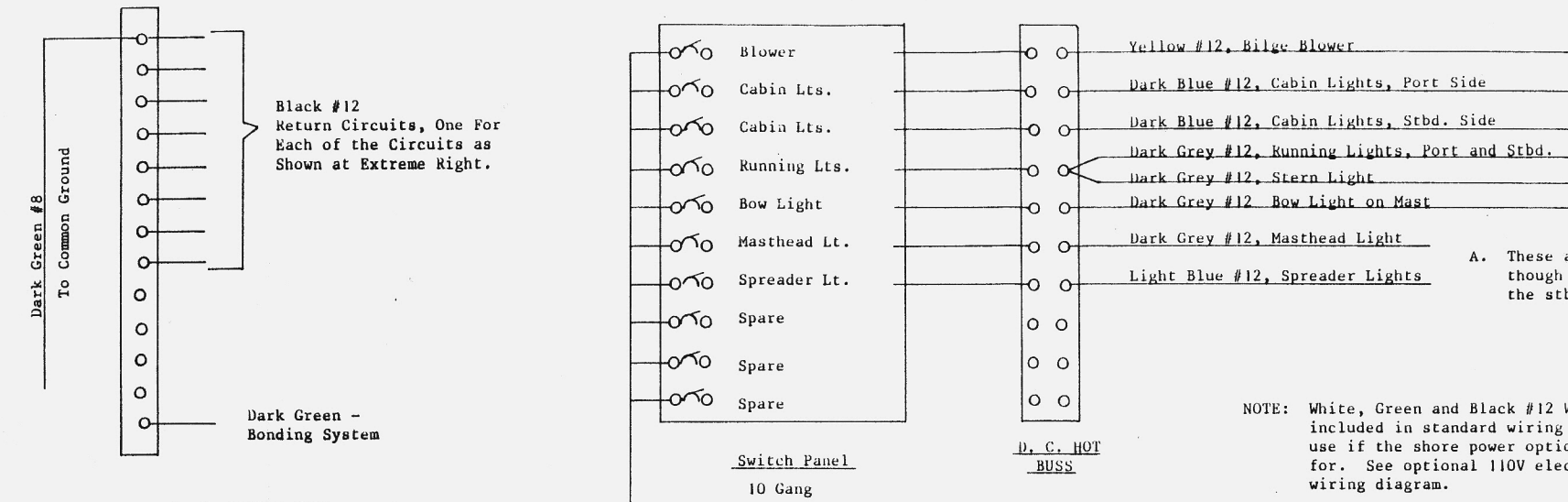

A. These are optional though they are shown on the stbd. panel

NOTE: White, Green and Black #12 Wires are included in standard wiring harness for use if the shore power option is called for. See optional 110V electrical wiring diagram.

Any deviation from this wire color coding due to shortages will be documented with a copy included in the boat owners kit.

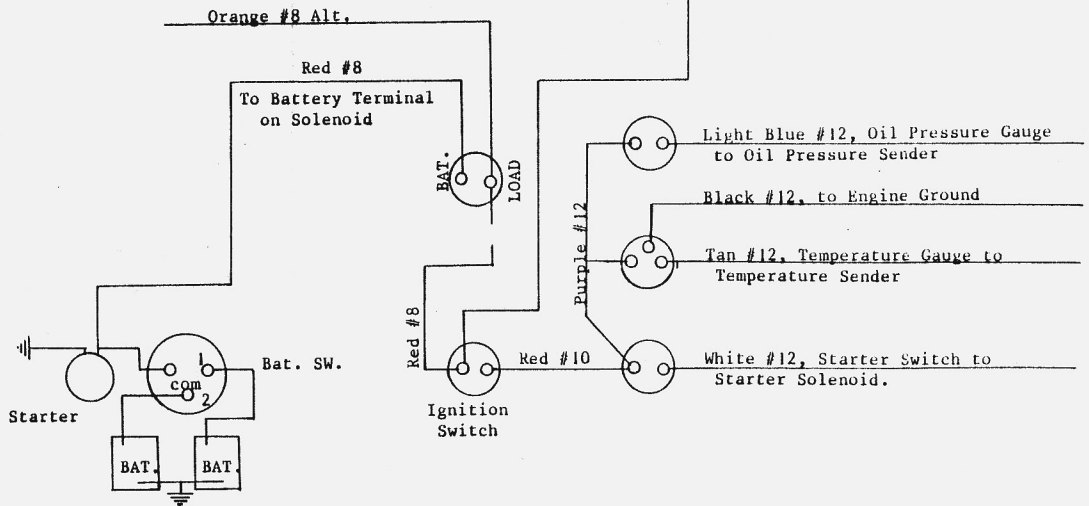

PEARSON YACHTS, DIVISION OF
GRUMMAN ALLIED INDUSTRIES, INC.
P-323 Dual Battery
12V Electrical Wiring Diagram

March 7, 1980